

# TB045

Book No. PK2-102Z5  
Serial No. 1455001-1456876

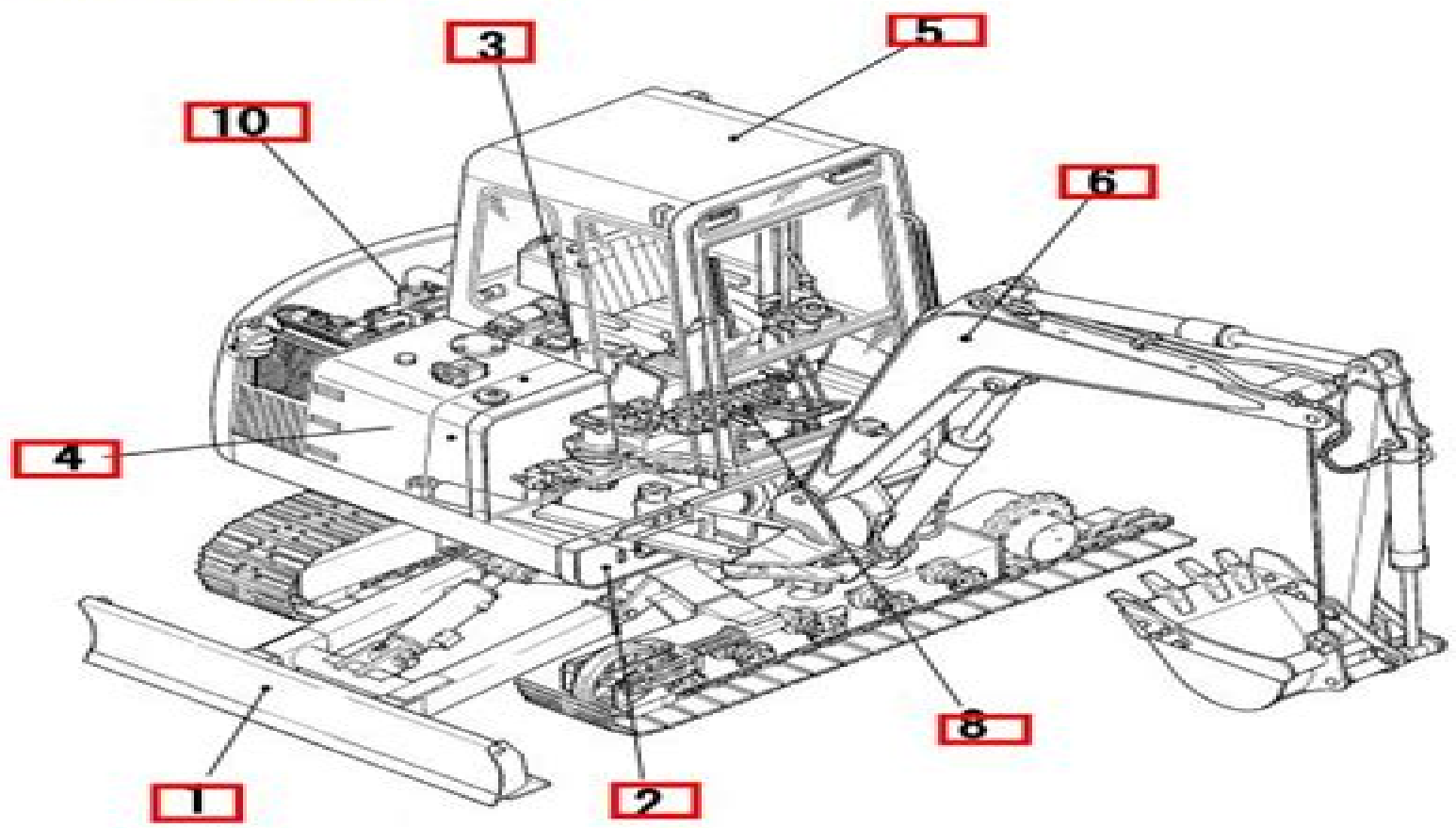

# Takeuchi 045 Service Manual

**Yicheng Fang**



**Takeuchi 045 Service Manual:**

**Moody's International Manual** ,1997     Moody's Transportation Manual ,1995     **Mergent International Manual** ,2002     **ICOT Journal** ,1986     *Japan Directory* ,1980     *Monographic Series* Library of Congress,     **Library of Congress Catalogs** Library of Congress,1976     **Forthcoming Books** Rose Army,2000     **Books in Print Supplement** ,1985     *Who's who in the West* ,1989     Service Manual (for) Yugo 45-55 Zastava Cars,     **Service Repair Manual** David Brown Tractors Ltd,1979     **Service Manual** Caterpillar Tractor Company (U.S.A),1983     **White: Shop Manual W-201 (I & T Shop Service Manuals, W-201)** Penton Staff,2000-05-24 Gas models 2 70 Diesel models 2 30 2 35 2 45 2 55 2 62 2 65 2 70 2 75 2 85 2 105 2 135 2 150 2 155     **John Deere 2240 Tractor Technical Service Repair Manual** ,1980-11-15     **Toyota Repair Manual Supplement for Chassis & Body** ,1985     **Toyota 2A-C, 4A-C, 4A-GE Engine** Toyota Jidōsha Kabushiki Kaisha,1985     **Toyota Corona Repair Manual for Chassis & Body** Toyota Jidōsha Kabushiki Kaisha. Overseas Service Department,1984     **Toyota W-50 5-speed Manual Transmission Repair Manual** Toyota Jidōsha Hanbai Kabushiki Kaisha. Service Training Department,1974     **American Service Manual** Champion Electric Corporation,1946

## Reviewing **Takeuchi 045 Service Manual**: Unlocking the Spellbinding Force of Linguistics

In a fast-paced world fueled by information and interconnectivity, the spellbinding force of linguistics has acquired newfound prominence. Its capacity to evoke emotions, stimulate contemplation, and stimulate metamorphosis is actually astonishing. Within the pages of "**Takeuchi 045 Service Manual**," an enthralling opus penned by a very acclaimed wordsmith, readers embark on an immersive expedition to unravel the intricate significance of language and its indelible imprint on our lives. Throughout this assessment, we shall delve to the book is central motifs, appraise its distinctive narrative style, and gauge its overarching influence on the minds of its readers.

<https://about.livewellcolorado.org/book/uploaded-files/index.jsp/Mini%20Cooper%20Service%20Manual%20.pdf>

### **Table of Contents Takeuchi 045 Service Manual**

1. Understanding the eBook Takeuchi 045 Service Manual
  - The Rise of Digital Reading Takeuchi 045 Service Manual
  - Advantages of eBooks Over Traditional Books
2. Identifying Takeuchi 045 Service Manual
  - Exploring Different Genres
  - Considering Fiction vs. Non-Fiction
  - Determining Your Reading Goals
3. Choosing the Right eBook Platform
  - Popular eBook Platforms
  - Features to Look for in an Takeuchi 045 Service Manual
  - User-Friendly Interface
4. Exploring eBook Recommendations from Takeuchi 045 Service Manual
  - Personalized Recommendations
  - Takeuchi 045 Service Manual User Reviews and Ratings
  - Takeuchi 045 Service Manual and Bestseller Lists

5. Accessing Takeuchi 045 Service Manual Free and Paid eBooks
  - Takeuchi 045 Service Manual Public Domain eBooks
  - Takeuchi 045 Service Manual eBook Subscription Services
  - Takeuchi 045 Service Manual Budget-Friendly Options
6. Navigating Takeuchi 045 Service Manual eBook Formats
  - ePub, PDF, MOBI, and More
  - Takeuchi 045 Service Manual Compatibility with Devices
  - Takeuchi 045 Service Manual Enhanced eBook Features
7. Enhancing Your Reading Experience
  - Adjustable Fonts and Text Sizes of Takeuchi 045 Service Manual
  - Highlighting and Note-Taking Takeuchi 045 Service Manual
  - Interactive Elements Takeuchi 045 Service Manual
8. Staying Engaged with Takeuchi 045 Service Manual
  - Joining Online Reading Communities
  - Participating in Virtual Book Clubs
  - Following Authors and Publishers Takeuchi 045 Service Manual
9. Balancing eBooks and Physical Books Takeuchi 045 Service Manual
  - Benefits of a Digital Library
  - Creating a Diverse Reading Collection Takeuchi 045 Service Manual
10. Overcoming Reading Challenges
  - Dealing with Digital Eye Strain
  - Minimizing Distractions
  - Managing Screen Time
11. Cultivating a Reading Routine Takeuchi 045 Service Manual
  - Setting Reading Goals Takeuchi 045 Service Manual
  - Carving Out Dedicated Reading Time
12. Sourcing Reliable Information of Takeuchi 045 Service Manual
  - Fact-Checking eBook Content of Takeuchi 045 Service Manual
  - Distinguishing Credible Sources
13. Promoting Lifelong Learning

- Utilizing eBooks for Skill Development
  - Exploring Educational eBooks
14. Embracing eBook Trends
- Integration of Multimedia Elements
  - Interactive and Gamified eBooks

### **Takeuchi 045 Service Manual Introduction**

In today's digital age, the availability of Takeuchi 045 Service Manual books and manuals for download has revolutionized the way we access information. Gone are the days of physically flipping through pages and carrying heavy textbooks or manuals. With just a few clicks, we can now access a wealth of knowledge from the comfort of our own homes or on the go. This article will explore the advantages of Takeuchi 045 Service Manual books and manuals for download, along with some popular platforms that offer these resources. One of the significant advantages of Takeuchi 045 Service Manual books and manuals for download is the cost-saving aspect. Traditional books and manuals can be costly, especially if you need to purchase several of them for educational or professional purposes. By accessing Takeuchi 045 Service Manual versions, you eliminate the need to spend money on physical copies. This not only saves you money but also reduces the environmental impact associated with book production and transportation. Furthermore, Takeuchi 045 Service Manual books and manuals for download are incredibly convenient. With just a computer or smartphone and an internet connection, you can access a vast library of resources on any subject imaginable. Whether you're a student looking for textbooks, a professional seeking industry-specific manuals, or someone interested in self-improvement, these digital resources provide an efficient and accessible means of acquiring knowledge. Moreover, PDF books and manuals offer a range of benefits compared to other digital formats. PDF files are designed to retain their formatting regardless of the device used to open them. This ensures that the content appears exactly as intended by the author, with no loss of formatting or missing graphics. Additionally, PDF files can be easily annotated, bookmarked, and searched for specific terms, making them highly practical for studying or referencing. When it comes to accessing Takeuchi 045 Service Manual books and manuals, several platforms offer an extensive collection of resources. One such platform is Project Gutenberg, a nonprofit organization that provides over 60,000 free eBooks. These books are primarily in the public domain, meaning they can be freely distributed and downloaded. Project Gutenberg offers a wide range of classic literature, making it an excellent resource for literature enthusiasts. Another popular platform for Takeuchi 045 Service Manual books and manuals is Open Library. Open Library is an initiative of the Internet Archive, a non-profit organization dedicated to digitizing cultural artifacts and making them accessible to the public. Open Library hosts millions of books, including both public domain works and contemporary titles. It also allows users to

borrow digital copies of certain books for a limited period, similar to a library lending system. Additionally, many universities and educational institutions have their own digital libraries that provide free access to PDF books and manuals. These libraries often offer academic texts, research papers, and technical manuals, making them invaluable resources for students and researchers. Some notable examples include MIT OpenCourseWare, which offers free access to course materials from the Massachusetts Institute of Technology, and the Digital Public Library of America, which provides a vast collection of digitized books and historical documents. In conclusion, Takeuchi 045 Service Manual books and manuals for download have transformed the way we access information. They provide a cost-effective and convenient means of acquiring knowledge, offering the ability to access a vast library of resources at our fingertips. With platforms like Project Gutenberg, Open Library, and various digital libraries offered by educational institutions, we have access to an ever-expanding collection of books and manuals. Whether for educational, professional, or personal purposes, these digital resources serve as valuable tools for continuous learning and self-improvement. So why not take advantage of the vast world of Takeuchi 045 Service Manual books and manuals for download and embark on your journey of knowledge?

### **FAQs About Takeuchi 045 Service Manual Books**

How do I know which eBook platform is the best for me? Finding the best eBook platform depends on your reading preferences and device compatibility. Research different platforms, read user reviews, and explore their features before making a choice. Are free eBooks of good quality? Yes, many reputable platforms offer high-quality free eBooks, including classics and public domain works. However, make sure to verify the source to ensure the eBook credibility. Can I read eBooks without an eReader? Absolutely! Most eBook platforms offer web-based readers or mobile apps that allow you to read eBooks on your computer, tablet, or smartphone. How do I avoid digital eye strain while reading eBooks? To prevent digital eye strain, take regular breaks, adjust the font size and background color, and ensure proper lighting while reading eBooks. What the advantage of interactive eBooks? Interactive eBooks incorporate multimedia elements, quizzes, and activities, enhancing the reader engagement and providing a more immersive learning experience. Takeuchi 045 Service Manual is one of the best book in our library for free trial. We provide copy of Takeuchi 045 Service Manual in digital format, so the resources that you find are reliable. There are also many Ebooks of related with Takeuchi 045 Service Manual. Where to download Takeuchi 045 Service Manual online for free? Are you looking for Takeuchi 045 Service Manual PDF? This is definitely going to save you time and cash in something you should think about.

**Find Takeuchi 045 Service Manual :**

~~mini-cooper service manual 2002~~

~~bmw alpina d3 price guide~~

~~at t answering machine manual~~

~~97 nissan 200sx diagrams~~

**suzuki every f6a service manual**

~~zenspirations letters patterning~~

**2006 porsche cayenne owners manual**

~~network printer manual~~

~~x220 tablet hardware maintenance manual~~

**zoology trivia questions and answers**

**network programming lab manual**

**economics march 2013 grade 12**

~~link belt lx160 service manual~~

~~boeing 777 maintenance manual~~

**audi a6 manual transmission canada**

**Takeuchi 045 Service Manual :**

Italy Travel Guide by Rick Steves Explore Italy! Get inspired with Rick Steves' recommended places to go and things to do, with tips, photos, videos, and travel information on Italy. Italy Tours & Vacations 2023 & 2024 Rick Steves Italy tours provide the best value for your trip to Europe. Our stress-free Italy vacations package together small groups, great guides, central ... Italy Guidebook for 2024 - Rick Steves Travel Store Rick's picks for sights, eating, sleeping; In-depth coverage of our favorite Italian destinations; Great self-guided neighborhood walks and museum tours ... One week in Italy - Rick Steves Travel Forum Jun 14, 2018 — Rome is amazing, but it will be hot. Our absolute favorite place in Italy is Lake Como---particularly Varenna. We also loved the Amalfi Coast, ... Italy's Amalfi Coast - Video - Rick Steves' Europe Advice on Italy Travel Plan - Rick Steves Travel Forum Jul 22, 2023 — In planning a trip, it helps to pick the exact specific museums and monuments you will see and what you will acquiesce to skipping. Then you ... Italy Itinerary Rick's Best Three-Week Trip to Italy. The big-ticket stops in Italy — Venice, the Cinque Terre, Florence, Rome, and the cluster south of Rome (Sorrento/Naples/ ... Rick Steves Italy (Travel Guide) This guide gives you an overview together with every little thing you need for planning a trip. How many days,



transportation, hotels, restaurants, sights, ... Ultra-Gash Inferno by Maruo, Suehiro Ultra-Gash Inferno is the ultimate compendium of Suehiro Maruo's most shocking and graphically precise work, containing nine psycho-nightmares never before ... Book review: Ultra-Gash Inferno - Yeah nah. Nov 5, 2020 — Because frankly, it is. This collection, while executed with the same fastidiously odd art - a mix of Expressionist weirdness and Taisho chic - ... Ultra Gash Inferno | Manga May 16, 2023 — Collection of surreal erotic grotesque stories from Suehiro Maruo which he released from 1981 to 1993. The stories are: 1. Putrid Night Read Ultra Gash Inferno for the first time a couple night ago ... Ultra Gash is good but the reproduction is pretty bloody awful! It needs a reprint alongside translations of his other works into English, but I ... Ultra Gash Inferno Read light novel online for free The best light novel reading site. Ultra-Gash Inferno - Eroticamanga Ultra-Gash Inferno is the ultimate compendium of Suehiro Maruo's most shocking and graphically precise work containing nine psycho-nightmares never before ... Comic Review: Oh God, My Eyes! Ultra Gash Inferno by ... Jul 6, 2012 — Ultra-Gash Inferno is a collection of nine short comics illustrated by Suehiro Maruo, the current heavy-weight champ of horror comics in Japan. Suehiro Maruo Ultra Gash Inferno Suehiro Maruo Ultra Gash Inferno ; Signed: No ; # of Pages: 214 ; Size: 6.67" x 9.5" x .4" 16.8 x 24.3 x 1.1cm ; Binding: Softcover ; Edition: First. Review: Ultra-Gash Inferno, by Suehiro Maruo Jan 2, 2022 — This manga is you-can't-tell-people-you're-reading-this disturbing. Although the collection contains a curious amount of eye-related incidents, ... Irs Form 6744 Answers - Fill Online, Printable, Fillable, Blank ... Form 6744 is an answer key for the IRS Volunteer Income Tax Assistance (VITA) program. It is used by volunteers to check their answers when preparing tax ... VITA/TCE Volunteer Assistor's Test/Retest Sep 25, 2023 — Volunteers who answer tax law questions, instruct tax law classes, prepare or correct tax returns, or conduct quality reviews of completed ... VITA/TCE Volunteer Assistor's Test/Retest Form 6744 - 2018 VITA/TCE Test. Table of Contents. Preface ... If you are entering your retest answers in Link & Learn Taxes, do not use this answer sheet . SOLUTION: Accounting Question I need the answers for the (2020 - Volunteer Income Tax Assistance Tests (VITA) form 6744). The questions are in the book that is freely available online in PDF ... Publication 6744 Answers - Fill Online, Printable, Fillable, ... Edit form 6744 answer key 2018. Rearrange and rotate pages, insert new and alter existing texts, add new objects, and take advantage of other helpful tools. VITA/TCE Training Guide Volunteers who answer tax law questions, instruct tax law classes, prepare ... key to the integrity of the VITA/TCE programs. Taxpayers will trust that all ... IRS Volunteer Oct 1, 2014 — You will be able to use this guide and other available resources to answer many questions that may arise while operating your VITA/TCE site. 2016 RETURNS Oct 20, 2016 — Form 6744 - 2016 VITA/TCE Test. Table of Contents. Preface ... If you are entering your test answers in Link & Learn Taxes, do not use this answer ... ACC 350 Module Five VITA Tests Answer Sheet ACC 350 Module Five VITA Tests Answer Sheet Record your answer to each question by overwriting the bracketed text in the right-hand column.